



.....
Medalist Pro Family
.....

Medalist Pro 2520 (ST52520A)
.....

Medalist Pro 2160 (ST52160A)
.....

ATA Interface drives
.....

Product Manual
.....

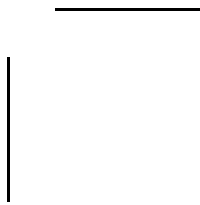
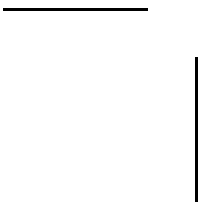
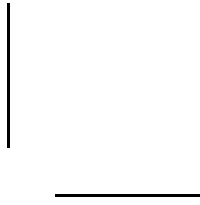
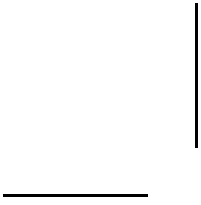

.....
Medalist Family
.....

Medalist Pro 2520 (ST52520A)
.....

Medalist Pro 2160 (ST52160A)
.....

ATA Interface drives
.....

Product Manual
.....



© 1997 Seagate Technology, Inc. All rights reserved

Publication Number: 36347-101, Rev. C, February 1997

Seagate, Seagate Technology and the Seagate logo are registered trademarks of Seagate Technology, Inc. Medalist is a trademark of Seagate Technology, Inc. Other product names are trademarks or registered trademarks of their owners.

Seagate reserves the right to change, without notice, product offerings or specifications. No part of this publication may be reproduced in any form without written permission from Seagate Technology, Inc.

Contents

Introduction	1
Quick specification chart	3
1.0 Specifications	5
1.1 Formatted Capacity	5
1.1.1 Standard Configuration	5
1.2 Physical organization	6
1.3 Functional specifications	6
1.4 Physical dimensions	7
1.5 Seek time	7
1.6 Multisegmented cache buffer	7
1.7 Start and stop times	8
1.8 Typical power-up and power-down sequence	8
1.9 Power-up sequence	9
1.9.1 Power-down sequence	9
1.10 Auto-park	9
1.11 Power specifications	9
1.11.1 Power management	9
1.11.2 Power consumption	11
1.12 Input noise	11
1.13 Environmental specifications	11
1.13.1 Ambient temperature	11
1.13.2 Temperature gradient	12
1.13.3 Altitude	12
1.13.4 Relative humidity	12
1.14 Shock and vibration	12
1.15 Acoustics	13
1.16 Reliability	13
1.17 Agency listings	13
1.18 Electromagnetic Compliance for the European Union	14

1.19 FCC verification	14
2.0 Configuring and mounting the drive	17
2.1 Handling and static-discharge precautions	17
2.2 I/O cable and connector.	18
2.3 Power connector	18
2.4 Options jumper block	19
2.4.1 Master/slave configuration	20
2.4.2 Alternate capacity jumper	21
2.4.3 Remote LED connection	21
2.4.4 Cable-select option	21
2.5 Mounting the drive	22
3.0 ATA interface	25
3.1 ATA Interface connector pin assignments	25
3.2 Command set	27
3.2.1 Identify drive command (ECH)	29
3.2.2 Set Features command (EFH)	32
3.2.3 Standby timer timeout period	34
3.2.4 Sleep command (99H, E6H)	34
3.2.5 Auto Relocation	34
3.2.6 S.M.A.R.T. command (B0H)	35
Appendix. Timing diagrams	37

Figures

Figure 1. Typical startup current profile	8
Figure 2. ATA interface connector	18
Figure 3. Connectors	19
Figure 4. Configuration settings	20
Figure 5. Connecting cable-selected drives	22
Figure 6. Mounting dimensions	23
Figure 7. ATA interface connector pin assignments	26
Figure 8. Programmed I/O timing without IORDY	37
Figure 9. Programmed I/O timing with IORDY	38
Figure 10. Multiword DMA timing	39

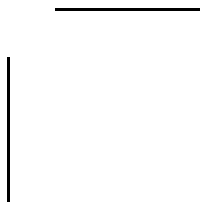
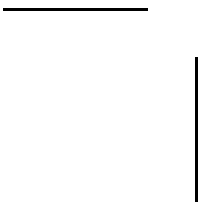
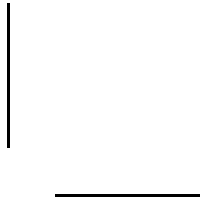
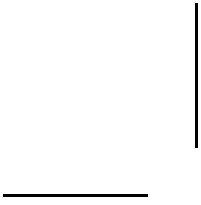

Introduction

This manual describes the functional, mechanical and interface specifications for the Medalist[®] Pro 2520 and Medalist Pro 2160 hard disc drives. The drives are referred to throughout this manual by their model numbers, ST52520A for the Medalist Pro 2520 and ST52160A for the Medalist Pro 2160.

Seagate[®] desktop products take a step into the future with the ST52520A and ST52160A. These drives feature MR heads and PRML recording technology, Fast ATA-2 performance, segmented cache, embedded servo technology, low noise, power management and S.M.A.R.T. capabilities.

MR heads and PRML recording technology provide the drives with increased areal density. This means that more data can be stored on a single disc. Only two discs are used in the ST52520A and ST52160A drives.

Fast ATA-2 performance means that the drives support PIO mode 4, multiword DMA mode 2 transfer modes and multiple block read/write. When the host chooses either transfer mode, the drives provide burst-transfer rates of up to 16.6 Mbytes per second. The multiple block read/write feature allows the drives to store several blocks of data in cache and transfer them in a single burst.

These drives use a 128-Kbyte segmented cache. Segmenting the cache provides a designated area where blocks of contiguous read or write data can be staged for transfer in a single burst.

The ST52520A and ST52160A drives have other features that ensure fast data throughput. Embedded servo technology allows the drives to position the heads for data retrieval efficiently and accurately while eliminating the periodic thermal recalibration that can interrupt during data transfers. These drives also use a 16-bit microprocessor and an intelligent controller that provides data streaming: direct data transfers between the drive and the host without microprocessor intervention. These features allow for a sustained data-transfer rate that facilitates video playback and other multimedia operations.

These drives support Active, Idle and Standby power-management modes. Power-saving modes can be controlled by the host computer. Standby mode reduces power consumption to 1 watt (typical) while retaining drive accessibility.

Self-Monitoring, Analysis and Reporting Technology (S.M.A.R.T.) is available on these drives. Implementation of this feature is discussed on page 35. To use the feature, you must have a BIOS, a software driver or application software that supports S.M.A.R.T.

The ATA commands with specific applications for these drives and the Seagate-unique commands the drives use are discussed in Section 3.0 on page 25. A complete list of the commands the drives support are found in the table on page 27.

The following is a summary of the drives' features:

Capacity

- 2.564 and 2.113 Gbytes formatted
- LBA translation support
- Available software driver that surpasses the 528-Mbyte barrier and 4,096 cylinder barrier limited by some system BIOSs
- Available software driver that provides expanded 32-bit disk access support for Windows 3.x

Performance

- Fast ATA-2 (Supports multiword DMA mode 2 and PIO mode 4 for up to 16.6-Mbyte-per-second burst transfer rates. Supports multiple block read/write.)
- 128-Kbyte segmented buffer
- 12-msec average read seek time
- 13-msec average write seek time
- Data streaming

Energy efficiency

- Active, Idle and Standby power-management modes
 - 1 watt typical power dissipation rating in Standby mode
-

Quick specification chart

The following table serves as a quick reference for the drives' performance specifications. These and other specifications are discussed in "Specifications" on page 5.

Drive specification	ST52520A	ST52160A
Guaranteed capacity (Gbytes) ($\times 10^9$ bytes)	2.564	2.113
Guaranteed sectors	5,009,760	4,127,760
Bytes per sector	512	512
Sectors per track	63	63
Logical read/write heads	16	16
Logical cylinders	4,970	4,095
Physical cylinders	6,536	6,536
Physical read/write heads	4	4
Physical discs	2	2
Areal density (Mbits/sq. in)	928.8	805.2
Data zones	19	19
Recording density (bits per inch)	138,011	119,609
Track density (tracks per inch)	6,730	6,730
Spindle speed (RPM)	5,397	5,397
Track-to-track seek time (msec typical)	3.5	3.5
Average read seek time (msec typical)	12	12
Average write seek time (msec typical)	13	13
Full-stroke seek time (msec typical)	25	25
Average latency (msec)	5.58	5.58
Internal data-transfer rate (Mbits per sec max)	63 to 116	55 to 97
External transfer rate (Mbytes per sec max)	16.6	16.6
Cache buffer (Kbytes)	128	128
ECC on-the-fly (bits)	65	65

continued

Drive specification	ST52520A	ST52160A
Height (inches max)	0.748	0.748
Width (inches max)	4.01	4.01
Depth (inches max)	5.38	5.38
Typical weight (lb)	1.0	1.0
Spinup current (max)	1.9A	1.9A
Seek power (typical)	7.9W	7.9W
Read/Write power and current (typical)	7.5W	7.5W
Idle total power (typical)	7.5W	7.5W
Standby/Sleep total power (typical)	4.3W	4.3W
Voltage tolerance (including noise): +5V	± 5%	± 5%
Voltage tolerance (including noise): +12V	± 5%	± 5%
Operating temperature (°C)	5 to 55°C	5 to 55°C

1.0 Specifications

1.1 Formatted Capacity

Medalist Pro drives are low-level formatted at the factory. You cannot low-level format them.

These drives support cylinder-head-sector (CHS) and logical-block addressing (LBA) translation modes. You can use the Identify drive (ECH) command to verify the address modes the drives support, the number of cylinders, sectors per track, total number of sectors, heads and other parameters. The Identify drives parameters are listed in Section 3.2.1 on page 29.

Notes:

1. DOS cannot access more than 2.147 Gbytes per partition. You must create 2 or more partitions to access the drive's full capacity.
2. One Mbyte equals one million bytes.
3. If the system BIOS does not support more than 4,096 cylinders, it can cause the computer to hang during boot, or it can truncate or wrap the cylinders. To resolve this issue the system BIOS needs to be modified: the cylinder register or variable must be increased from 12-bits to 16-bits to accommodate more than 4,096 cylinders.

1.1.1 Standard Configuration

ST52160A	CHS	LBA
Cylinders	4,095	N/A
Heads	16	N/A
Sectors	63	N/A
Guaranteed sectors	4,127,760	
Guaranteed capacity (Gbytes)	2.113	
ST52520A	CHS	LBA
Cylinders	4,970	N/A
Heads	16	N/A
Sectors	63	N/A
Guaranteed sectors	5,009,760	
Guaranteed capacity (Gbytes)	2.564	

1.2 Physical organization

	ST52520A	ST52160A
Read/write heads	4	4
Discs	2	2

1.3 Functional specifications

	ST52520A	ST52160A
Interface	ATA	ATA
Recording method	PRML (0,4,4)	PRML (0,4,4)
External data burst transfer rate:		
DMA mode 2 (Mbytes per sec)	16.6	16.6
PIO mode 4 (Mbytes per sec)	16.6	16.6
Internal data-transfer rate (Mbits per sec)	63 to 116	55 to 97
Spindle speed (RPM)	5,397 ± 0.5%	5,397 ± 0.5%
Cache size (Kbytes)	128	128
Logical cylinders	4,970	4,095
Physical cylinders	6,536	6,536
Bytes per sector	512	512
Areal density (Mbytes/sq. in)	928.8	805.2
Data zones	19	19
Recording density, max (BPI)	138,011	119,609
Track density (TPI)	6,730	6,730

Note. See Figure 10 on page 39 for multibyte DMA timing specifications. See Figure 8 on page 37 and Figure 9 on page 38 for PIO timing specifications.

1.4 Physical dimensions

The mounting dimensions are shown in Figure 6 on page 23.

Height, max	0.748 inch (19 mm)
Width, max	4.01 inches (101.8 mm)
Depth, max	5.38 inches (136.6 mm)
Weight	1.0 lb (0.45 Kg)

1.5 Seek time

Seek value is the interval between the time the actuator begins to move and the time the head has settled over the target track. Seek time is a true statistical average of at least 10,000 measurements of seek time. All measurements are taken under nominal conditions of temperature and voltage with the drive mounted horizontally. The specifications in the table below are defined as follows:

- Track-to-track seek time is the average of all possible single-track seeks in both directions.
- Average seek time is measured by executing seeks in both directions between random cylinders.
- Full-stroke seek time is half the time needed to seek from track 0 to the maximum track and back to track 0.

Track-to-track seek time	Average/typical seek time	Full-stroke seek time	Average latency
3.5 msec typ	11 msec seek	25 msec typ	5.58 msec
4.5 msec max	12 msec read	27 msec max	
	13 msec write		

Note. Host overhead varies between systems and cannot be specified. Drive internal overhead is measured by issuing a no-motion seek. Overhead is typically less than 0.5 msec.

1.6 Multisegmented cache buffer

The Medalist Pro ST52520A and ST52160A drives are available with a 128-Kbyte, multisegmented cache buffer that improves performance by reducing access times.

Read look-ahead. The drive uses the read segments to store additional logical sectors, after the last requested sector, into a buffer before the computer requests the additional sectors. The cache buffer stores data

from the start of a read until the buffer segment is full or until another command is received.

Write immediate. The drive uses the write segment to store write commands and data. After the drive receives all of the data for the command, it issues a write complete. Then, the drive writes the data to the disc.

Write merging. The drive accepts contiguous write commands and executes them as one command.

1.7 Start and stop times

Within 20 seconds after power is applied, the drive is ready. Within 15 seconds after power is removed, the drive spindle stops rotating.

1.8 Typical power-up and power-down sequence

This section describes typical power-up and power-down sequences to assist you in evaluating the drive's performance. They are not performance specifications. A typical startup current profile is shown in Figure 1. Startup current profiles are unique for each drive.

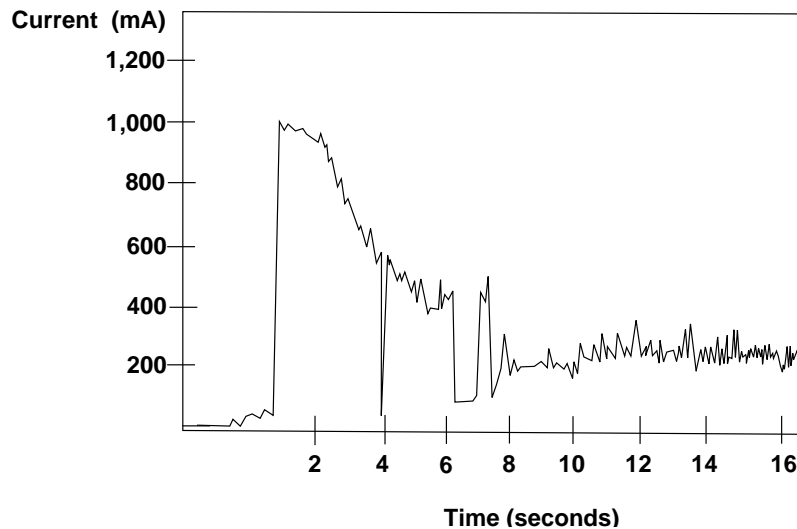

Figure 1. Typical startup current profile

1.9 Power-up sequence

1. Power is applied to the drive.
2. When power is applied, the LED stays on for about 1 second.
3. The spindle motor reaches operating speed in about 4 seconds.
4. The magnetic actuator-lock releases the actuator.
5. The drive achieves final speed-control lock.
6. The heads position over track 0 and the drive is ready.

1.9.1 Power-down sequence

Caution. Do not move the drive until the motor has come to a complete stop.

1. The power is turned off.
2. Within 15 seconds, the drive spindle stops rotating.
3. The read/write heads automatically move to the landing zone, which is inside the maximum data cylinder.
4. The magnetic actuator-lock mechanism locks the arm. This completes the power-down sequence.

1.10 Auto-park

During power-down, the read/write heads automatically move to the landing zone. The heads park inside the maximum data cylinder and the magnetic actuator-lock engages. When power is applied, the heads recalibrate to track 0.

1.11 Power specifications

1.11.1 Power management

The drive supports Active, Idle and Standby power-management modes. The power-management commands the drive supports are listed in the table on page 27. The table on page 11 shows the average typical power consumption rates for each power-management mode. The test criteria for each mode is defined below. The Idle and Standby timers are disabled at the factory.

All measurements were taken at the drive power connector. A true RMS

meter is used to measure all modes except Standby. A DMM is used for Standby measurements.

1.11.1.1 Active mode

During the Active mode, the drive is involved in spinup, seeking or read/write activities. The table on page 11 shows the typical power-consumption rates for these activities.

- **Spinup.** Spinup mode is entered from the Standby mode. The drive brings the spindle and discs up to operating speed. Power in this mode is defined as the peak power after starting spinup.
- **Seeking.** Seek mode is entered from Idle mode. The read/write heads are moved to a specific location on the disc surface in preparation for reading from or writing to the disc. Read/write electronics are powered down but servo electronics are active. Typical power is defined as the power average of executing random seeks with a 2-revolution (22.2 msec) dwell between Seek commands.
- **Read/write.** Read/write mode is entered from Idle mode. Read/write electronics are activated and the servo is on track. The drive reads from or writes to the disc.

1.11.1.2 Idle mode

The Idle mode is entered 1 minute after the last disk I/O activity. The motor is up to speed and the actuator is repositioned once every minute. This mode uses an algorithm that minimizes head media interface stresses. The drive can enter Idle mode from either Active or Standby mode.

1.11.1.3 Standby mode

The spindle is stopped, the heads are parked in the landing zone, the actuator is latched and some of the drive electronics are powered down.

Note. When recovering from Standby or Sleep mode, you must allow the drive to post ready before reporting a timeout. The drive can take up to 20 seconds to post ready. In a master and slave configuration, the master can wait up to 31 seconds for the slave to complete diagnostics before posting ready.

1.11.1.4 Sleep mode

The sleep mode implementation is the same as Standby mode.

1.11.2 Power consumption

In the table below, the values apply at the drive power connector. Current was measured with an RMS DC ammeter.

	Spinup	Seeking	Read/ write	Idle	Standby
Current at +12V					
Amps max	1.9A	—	—	—	—
RMS amps typ	—	.49	.45	.45	.19
Watts typ	—	5.8	5.4	5.4	2.3
Current at +5V					
RMS amps typ	—	.42	.42	.42	.40
Watts typ	—	2.1	2.1	2.1	2.0
Power					
Total watts typ	—	7.9W	7.5W	7.5W	4.3W

1.12 Input noise

	+5V	+12V
Voltage tolerance (including noise)	± 5%	± 5%
Input noise frequency (max)	25 MHz	25 MHz
Input noise (max, peak-to-peak)	100 mV	240 mV

1.13 Environmental specifications

1.13.1 Ambient temperature

Operating	5° to 55°C (41° to 131°F)
Nonoperating	−40° to 70°C (−40° to 158°F)

Note. The system must provide sufficient air movement to maintain a surface temperature of the aluminum base below 55°C.

1.13.2 Temperature gradient

Operating	20°C per hour (36°F per hour)
Nonoperating	30°C per hour (54°F per hour)

1.13.3 Altitude

Operating	-1,000 ft. to 10,000 ft. (-305 m to 3,048 m)
Nonoperating	-1,000 ft. to 40,000 ft. (-305 m to 12,192 m)

1.13.4 Relative humidity

Operating	8% to 80% noncondensing Maximum wet bulb 29.4°C (85°F)
Maximum operating gradient	10% per hour
Nonoperating	5% to 95% noncondensing Maximum wet bulb 35°C (95°F)

1.14 Shock and vibration

All shock and vibration specifications apply when the drive is mounted as recommended in Section 2.5 on page 22, with the input levels measured at the drive mounting screws. Shock measurements are based on an 11 msec, half sine wave shock pulse, not to be repeated more than twice per second.

During normal operating shock and vibration, there is no physical damage to the drive or performance degradation. During nonoperating shock and vibration, the read/write heads are positioned in the landing zone.

During abnormal operating shock and vibration, there is no physical damage to the drives although performance may be degraded during the shock or vibration episode. When normal operating shock levels resume, the drive meets its performance specifications.

	Operating	Abnormal	Nonoperating
Shock	2 Gs	10 Gs	75 Gs
5–22 Hz vibration	0.020-inch displacement	0.030-inch displacement	0.160-inch displacement
22–350 Hz vibration	0.50 Gs	0.75 Gs	4.00 Gs

1.15 Acoustics

This table shows the overall A-weighted acoustic sound power and sound pressure levels for the drives. All measurements are generally consistent with ISO document 7779. Acoustic measurements are taken under essentially free-field conditions over a reflecting plane. The drive is oriented with the top cover up for all tests.

Overall A-weighted Value	Idle	Seek
Sound power, typ (bels)	3.4	4.0
Sound power, max (bels)	3.7	4.3
Sound pressure, typ (dBA)	27	30
Sound pressure, max (dBA)	30	33

1.16 Reliability

Read error rates are measured with automatic retries and data correction with ECC enabled and all flaws re-allocated. The mean time between failures (MTBF) is measured at nominal power at sea level and an ambient temperature of 25°C.

Nonrecoverable read errors	1 per 10 ¹³ bits transferred
Seek errors	1 per 10 ⁷ physical seeks
Contact start/stops	50,000 cycles
MTBF	500,000 power-on hours
Service life	5 years

1.17 Agency listings

This drives are listed by agencies as follows:

- Recognized in accordance with UL478 and UL1950
- Certified to CSA C22.2 No. 220-M1986 and CSA C22.2 No. 950
- Certified to VDE 0805/05.90 and EN 60950/1.88 as tested by VDE

1.18 Electromagnetic Compliance for the European Union

If this model has the CE Marking, it complies with the European Union requirements of the Electromagnetic Compatibility Directive 89/336/EEC of 03 May 1989 as amended by Directive 92/31/EEC of 28 April 1992 and Directive 93/68/EEC of 22 July 1993.

Seagate uses an independent laboratory to confirm compliance to the above directives. The drive was tested in a representative system for typical applications. The selected system represents the most popular characteristics for test platforms. The system configurations include:

- 486, Pentium, and PowerPC microprocessors
- 3.5-inch floppy disc drives
- Keyboard
- Monitor/display

Although the test system with this Seagate model complies to the directives, we cannot guarantee that all systems will comply. The computer manufacturer or system integrator shall confirm EMC compliance and provide CE Marking for their product. The drive is not meant for external use (without properly designed enclosure, shielded I/O cable, etc.) and that a terminator should be used on all unused I/O ports.

1.19 FCC verification

The Medalist Pro ATA interface drives are intended to be contained solely within a personal computer or similar enclosure (not attached to an external device). As such, a drive is considered to be a subassembly even when individually marketed to the customer. As a subassembly, no Federal Communications Commission authorization, verification or certification of the device is required.

Seagate Technology, Inc. has tested these drives in an enclosure as described above to ensure that the total assembly (enclosure, disc drives, motherboard, power supply, etc.) does comply with the limits for a Class B computing device, pursuant to Subpart J of Part 15 of the FCC rules. Operation with noncertified assemblies is likely to result in interference to radio and television reception.

Radio and television interference. This equipment generates and uses radio frequency energy and, if not installed and used in strict accordance with the manufacturer's instructions, may cause interference to radio and television reception.

This equipment is designed to provide reasonable protection against

such interference in a residential installation. However, there is no guarantee that interference will not occur in a particular installation. If this equipment does cause interference to radio or television, which can be determined by turning the equipment on and off, you are encouraged to try one or more of the following corrective measures:

- Reorient the receiving antenna.
- Move the device to one side or the other of the radio or TV.
- Move the device farther away from the radio or TV.
- Plug the equipment into a different outlet so that the receiver and computer are on different branch outlets.

If necessary, you should consult your dealer or an experienced radio/television technician for additional suggestions. You may find helpful the following booklet prepared by the Federal Communications Commission: *How to Identify and Resolve Radio-Television Interference Problems*. This booklet is available from the Superintendent of Documents, US Government Printing Office, Washington, DC 20402. Refer to publication number 004-000-00345-4.

Note. This digital apparatus does not exceed the Class B limits for radio noise emissions from computer equipment as set out in the radio interference regulations of the Canadian Department of communications.

Le présent appareil numérique n'émet pas de bruits radioélectriques dépassant les limites applicables aux appareils numériques de Classe B prescrites dans le règlement sur le brouillage radioélectrique édicté par le Ministère des Communications du Canada.

Sicherheitsanleitung

1. Das Gerrät ist ein Einbaugerät, das für eine maximale Umgebungstemperatur von 55°C vorgesehen ist.
2. Zur Befestigung des Laufwerks werden 4 Schrauben 6-32 UNC-2A benötigt. Bei seitlicher Befestigung darf die maximale Länge der Schrauben im Chassis nicht mehr als 5,08 mm und bei Befestigung an der Unterseite nicht mehr als 5,08 mm betragen.
3. Als Versorgungsspannungen werden benötigt:
+5V \pm 5% 0.55A
+12V \pm 5% 0.35A (1,9A für ca. 30 Sek. für \pm 10%)
4. Die Versorgungsspannung muss SELV entsprechen.
5. Alle Arbeiten an der Festplatte dürfen nur von ausgebildetem Servicepersonal durchgeführt werden. Bitte entfernen Sie nicht die Aufschriftenschilder des Laufwerkes.
6. Der Einbau des Laufwerkes muss den Anforderungen gemäss DIN IEC 950 V DE 0805/05.90 entsprechen.

2.0 Configuring and mounting the drive

This section contains the specifications and instructions for configuring and mounting the drive.

2.1 Handling and static-discharge precautions

After you unpack the drive, and before you install it in a system, be careful not to damage it through mishandling. Observe the following standard handling and static-discharge precautions:

Caution:

- Keep the drive in its static-shielded bag until you are ready to complete the installation. Do not attach any cables to the drive while it is in its static-shielded bag.
- Before handling the drive, put on a grounded wrist strap, or ground yourself frequently by touching the metal chassis of a computer that is plugged into a grounded outlet. Wear a grounded wrist strap throughout the entire installation procedure.
- Handle the drive by its edges or frame only.
- The drive is extremely fragile—handle it with care. Do not press down on the drive top cover.
- Always rest the drive on a padded, antistatic surface until you mount it in the computer.
- Do not touch the connector pins or the printed circuit board.
- Do not remove the factory-installed labels from the drive or cover them with additional labels. Removal voids the warranty. Some factory-installed labels contain information needed to service the drive. Other labels are used to seal out dirt and contamination.

2.2 I/O cable and connector

The drive uses a 40-pin, male I/O connector with two rows of twenty pins each and a notch for keying. Pin 20 is removed for keying purposes. A drawing of the I/O connector is shown in Figure 2. Pin 1 is located near the 4-pin power connector when the I/O connector is mounted.

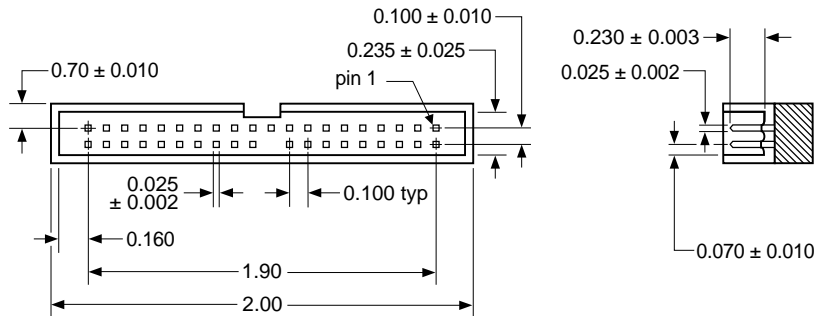

Figure 2. ATA interface connector

The table below lists recommended parts for the mating connector. You can use equivalent parts.

Part	Description	3M part number
Connector	40-pin	3M-3417-7000
Connector	40-pin	3M-3448-2040
Flat cable	AWG28 (stranded)	3M-3365-40

To ensure the integrity of your data, use a 40-connector, nonshielded I/O cable with a maximum length of 18 inches (46 centimeters).

2.3 Power connector

The drive uses a standard 4-pin, male power connector. We recommend the following part number or their equivalents for the mating connector.

Part	Description	Part number
Connector	Housing	AMP 1-480424-0
Connector	Pin (loose piece)	AMP 60619-4
Connector	Pin (Reel)	AMP 6117-4
Cable	18 AWG	

2.4 Options jumper block

The options jumper block (J5), shown in Figure 3, is used to configure the drives for operation. It is the 8-pin dual header between the I/O connector and the power connector. Pin 1 is located next to the power connector and is farthest from the printed circuit board. It accepts 0.1-inch jumpers. The options jumper block is used to:

- Configure the drive for single-drive operation
- Configure the drive as master with an ATA-compatible slave
- Configure the drive as the slave
- Configure the drive for alternate capacity
- Configure the drive for cable select
- Install a remote LED

The jumper settings for these options are shown in Figure 4 on page 20. The drive is shipped with a spare jumper attached to pins 6 and 8. Use this jumper to configure the drive.

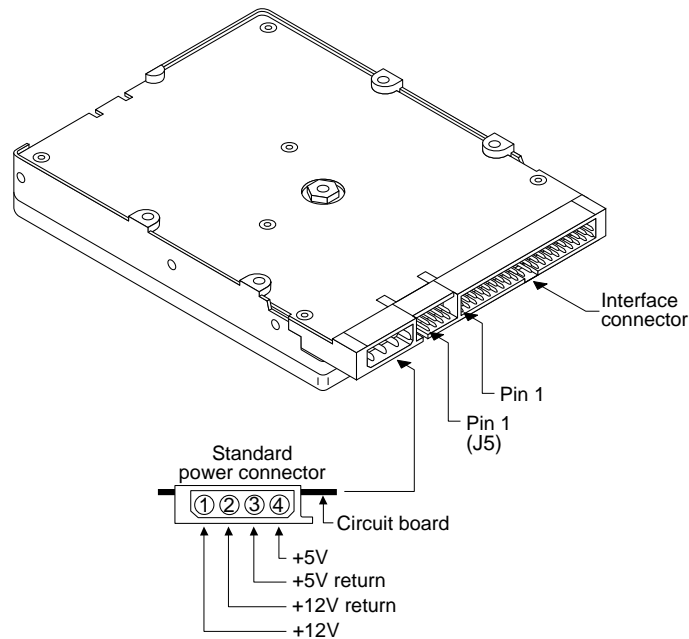

Figure 3. Connectors

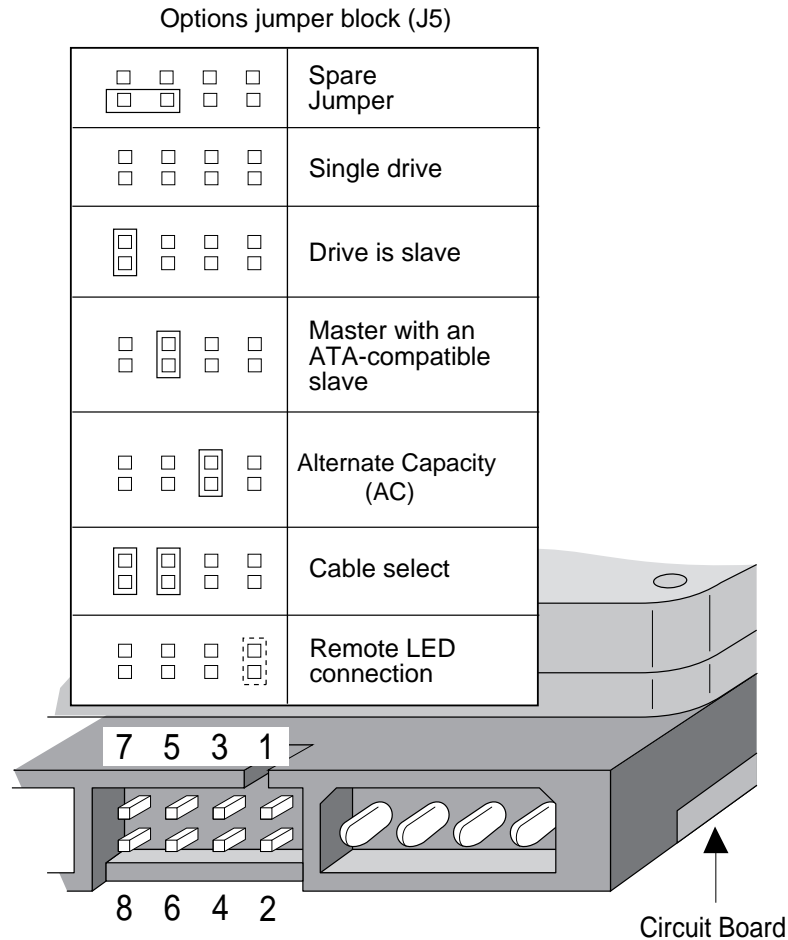

Figure 4. Configuration Settings

2.4.1 Master/slave configuration

Use the following settings to configure the drive as master or slave.

One drive only. The drive is configured at the factory for single-drive operation. No jumpers are required for single-drive operation. The spare jumper on pins 6 and 8 does not affect drive operation.

Drive as master with an ATA-compatible slave. Place a jumper on pins 5 and 6.

Drive as slave. Place a jumper on pins 7 and 8.

2.4.2 Alternate capacity jumper

This jumper lowers the drive capacity by setting the default translation to 1,024 cylinders. Some BIOSs that only auto-detect may require this jumper. Place a jumper on pins 3 and 4 of the J5 options jumper block to enable this option. When installing this jumper, you may need third-party partitioning software to achieve full capacity of the drive.

2.4.3 Remote LED

You can connect a remote LED to pins 1(-) and 2(+) of the options jumper block (J5). Do not install a shunt jumper on these pins.

Because the jumper block uses a 0.1-inch connector, you may need to replace the current connector. Use Seagate connector part number 10562-001 or an equivalent.

2.4.4 Cable-select option

Computers that use cable-select determine the master and slave drives by selecting or deselecting pin 28, CSEL, on the interface bus. Master and slave drives are determined by their physical position on the cable.

- The drive plugged into the I/O connector that carries the CSEL signal is the master.
- The drive plugged into the I/O connector that does not carry the CSEL signal is the slave.

To configure the drives for computers that use cable select:

- Install jumpers on pins 5 and 6 and pins 7 and 8 as shown in Figure 4 on page 20.
- Connect the drives to the cable as shown in Figure 5 on page 22.

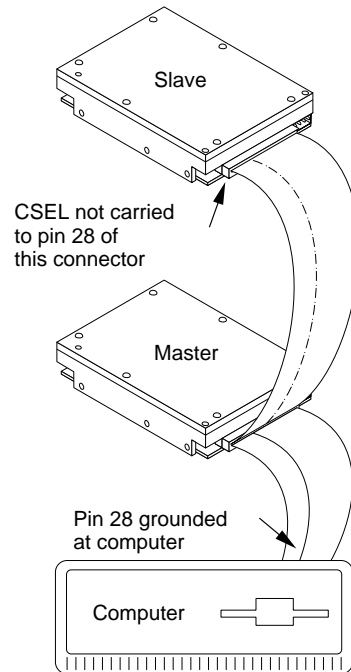

Figure 5. Connecting cable-selected drives

2.5 Mounting the drive

You can mount the drive in any orientation.

Use the set of mounting guidelines below that are appropriate to the type of mounting holes used: either bottom mounting holes or side mounting holes. Refer to Figure 6 on page 23 for mounting dimensions.

Bottom mounting holes. Insert four 6-32 UNC screws in the four bottom mounting holes as shown in Figure 6.

Caution. Do not insert the bottom mounting screws more than 0.20 inches (6 turns) into the drive frame.

Side mounting holes. Use four 6-32 UNC screws in four of the six available side mounting holes as shown in Figure 6. Use two mounting holes on each side of the drive.

Caution. Do not insert the side mounting screws more than 0.20 inches (6 turns) into the drive frame. If you use a screw that is too long, you risk damaging the drive's circuit board.

In the following figure, all dimensions are in inches and millimeters (mm).

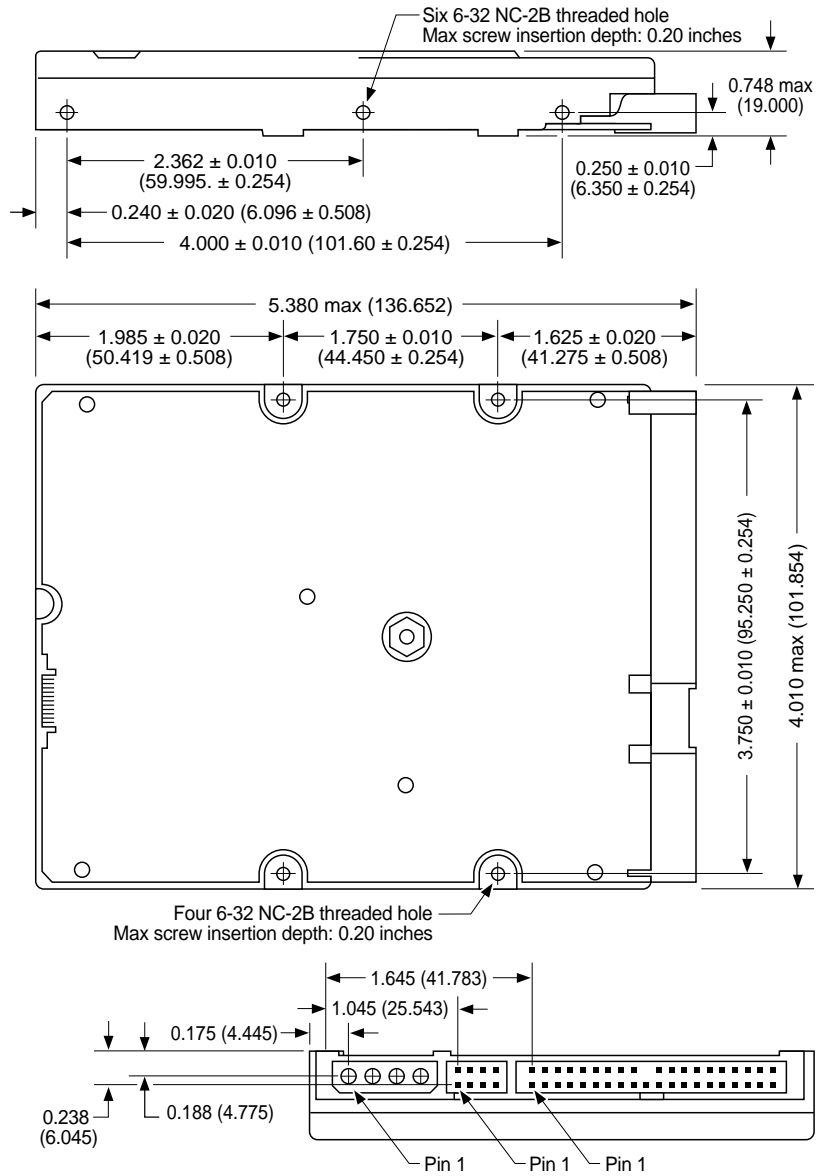

Figure 6. Mounting dimensions

3.0 ATA interface

The drives use an ATA-3 interface. The interface complies with *ANSI ATA (AT Attachment) Interface X3T10 Rev. 6.0*, *SFF 8011: ATA Timing Extension for Local Bus Attachments, Rev. 2.0* and *SFF 8019: Identify drives Data for drives Under 8 GB*. The ATA commands that the drives support are listed on pages 27 and 28. Commands and features with specific applications for these drives are also discussed in this section.

The ATA interface consists of single-ended, TTL-compatible receivers and drivers that use an asynchronous interface protocol. The drivers can sink up to 24 mA and drive a load up to 300 pF. The integrity of the ATA interface is affected by the interface cable. It is designed to support a 40-conductor, nonshielded interface cable with a maximum length of 18 inches (46 centimeters).

3.1 ATA Interface connector pin assignments

The signal name and signal direction for each I/O connector pin is shown in Figure 7 on page 26. See the *Seagate ATA Interface Reference Manual*, publication number 36111-xxx, for a complete description of each pin.

Signal names are shown in upper-case letters. If the signal name is followed by a minus sign (–), the signal is active low. Otherwise, the signal is active high.

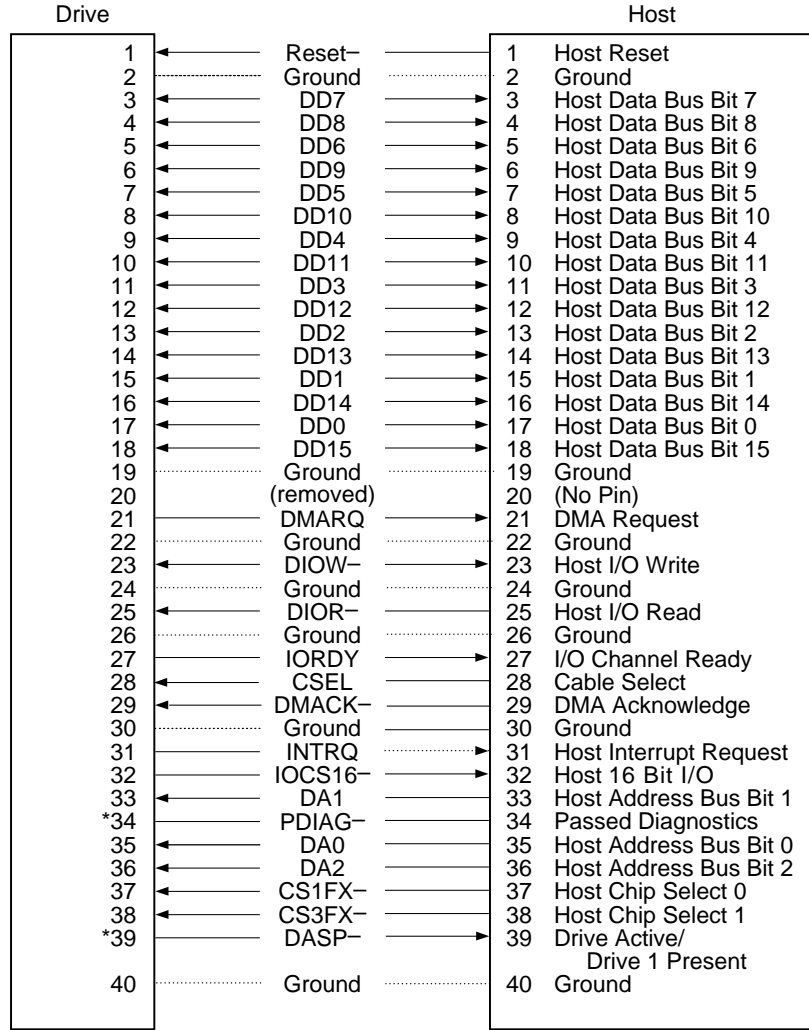

*Drive-to-drive signals

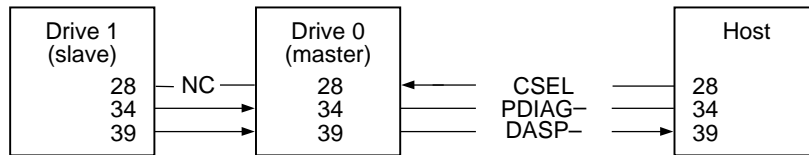

Figure 7. ATA interface connector pin assignments

3.2 Command set

This section lists all of the ATA commands the drives use. Only the commands with unique implementation for the drives are discussed in this manual. For information about the ATA interface, refer to *Working Draft X3T10.2008D Rev. 6, Information Technology—AT Attachment-3 Interface ATA-3*. Additional information about the drive commands and features is provided in *Seagate ATA Interface Reference Manual, 36311-xxx, Small Form Factor Specification, SFF-8011 Rev 1.1, September 18, 1993*, and *Small Form-Factor Committee Specification Draft SFF-8055i, January 8, 1996, Revision 1.0, Preliminary Document*.

The table below lists all commands implemented in the drives. It uses the following abbreviations:

- FR Features register
- SC Sector Count register
- SN Sector Number register
- CY Cylinder register
- DH Drive/Head register
- n This register does not contain a valid parameter for this command.
- y This register contains a valid parameter for this command. In the Drive/Head register, both the drive and head parameters are valid for this command.
- D The Drive/Head register contains a valid drive parameter for this command. The head parameter is not valid for this command.

Note. Read DMA, Read Long, Read Sector, Read Verify Sector, Write DMA, Write Long and Write Sector support with retry and without retry commands.

Command name	Command code (in hex)	Parameters used				
		FR	SC	SN	CY	DH
Active and Set Idle Timer	FB	n	y	n	n	D
Active Immediate	F9	n	n	n	n	D
Check Idle Mode	FD	n	y	n	n	D
Check Power Mode	98, E5	n	y	n	n	D
Execute Drives Diagnostic	90	n	n	n	n	D

continued

continued from previous page

Command name	Command code (in hex)	Parameters used				
		FR	SC	SN	CY	DH
Identify drives	EC	n	n	n	n	D
Idle	97, E3	n	y	n	n	D
Idle and Set Idle Timer	FA	n	y	n	n	D
Idle Immediate	95, F8, E1	n	n	n	n	D
Initialize Drive Parameters	91	n	y	n	n	y
Read DMA	C8, C9	—	y	y	y	y
Read Long	22, 23	n	y	y	y	y
Read Multiple	C4	n	y	y	y	y
Read Sector	20, 21	n	y	y	y	y
Read Sector Buffer	E4	n	n	n	n	D
Read Verify Sector	40, 41	n	y	y	y	y
Recalibrate	1X	n	n	n	n	D
Seek	7X	n	n	y	y	y
Set Features	EF	y	n	n	n	D
Set Multiple Mode	C6	n	y	n	n	D
Sleep	99, E6	n	n	n	n	D
S.M.A.R.T.	B0	y	y	n	y	y
Standby	96, E2	n	n	n	n	D
Standby Immediate	94, E0	n	n	n	n	D
Write DMA	CA, CB	—	y	y	y	y
Write Long	32, 33	n	y	y	y	y
Write Multiple	C5	n	y	y	y	y
Write Sector	30, 31	n	y	y	y	y
Write Sector Buffer	E8	n	n	n	n	D

3.2.1 Identify drive command (ECH)

The Identify drive parameters for the drives are listed in the table below.

Note. If the alternate capacity jumper is installed on the ST52520A, the drive capacity is reduced in Word 1 to 1,024 cylinders.

Word	Description	STValue
0	Configuration	0040 0400 _H Fixed drives
1	Number of logical cylinders	ST52520A = 4,970 ST52160A = 4,095
2	Reserved	0000
3	Number of logical heads	16
4	Vendor specific	36540
5	Vendor specific	580
6	Number of logical sectors per track	63
7–9	Vendor specific	0000
10–19	Serial number (20 ASCII characters)	drive-unique
20	Vendor specific	3
21	Vendor specific	224
22	ECC bytes (R/W Long)	0004 _H
23–26	Firmware revision (8 ASCII characters)	drive-unique
27–46	Model number (40 ASCII characters)	ST52520A ST52160A
47	Vendor specific	8010 _H
48	Reserved	0000
49	Capabilities	0B01 _H 0001 _H IORDY supported
50	Reserved	0000

continued

continued from previous page

Word	Description	STValue
51	PIO data-transfer cycle timing mode	0200H
52	Obsolete	0200H
53	Current valid	0003H 0001H words 54–58, 64–70 valid
54	Number of current logical cylinders	ST52520A = 4,970 ST52160A = 4,095
55	Number of current logical heads	16
56	Number of current sectors	63
57–58	Current capacity in sectors	ST52520A = 5,009,760 (CHS) ST52160A = 4,127,760 (CHS)
59	xxH = Current setting for number of sector that can be transferred per interrupt on Read/Write Multiple command	0000
60–61	Total number of user addressable LBA sectors	ST52520A = 5,009,760 ST52160A = 4,127,760
62	Obsolete	0000
63	Multiword DMA transfer mode active	0107H Mode 0 is active Modes 0, 1, and 2 supported
64	Advanced PIO transfer mode supported	0003H Modes 3 and 4 supported
65	Minimum multiword DMA transfer cycle time per word	120 nsec
66	Mfg. Recommended multiword DMA transfer cycle time	120 nsec

Word	Description	STValue
67	Minimum PIO transfer cycle time without flow control	240 nsec
68	Minimum PIO transfer with IORDY flow control	120 nsec
69–79	Reserved	0000
80	Major version number	0007 _H supports ATA-3 supports ATA-2 supports ATA-1
81	Minor version number	0000 Not supported
82	Command set support	0000 Not supported
83	Command set support	0000 Not supported
84–127	Reserved	
128	Security status	0000
129–159	Vendor specific	
160–255	Reserved	

3.2.2 Set Features command (EFH)

The Set Features command (command code EFH) allows the user to enable and disable the multisegmented cache and Auto Relocation features and to identify the transfer modes the drive uses. The multisegmented buffer consists of Read Look-ahead and write-immediate and write-merging features. The table below lists the features the drives support. The features that are set to default by the factory are indicated in the Feature column.

To use the command:

1. Write the Feature value to the Features register.
2. Write the Set Features command to the command register.

Note. If the value in the Features register is not supported or is invalid, the drives post an Aborted Command error.

At power-on or after a hard reset, the feature selections are restored to the factory-default values.

The table below shows alterable features that the drives support. Values that are preset at the factory are indicated as default in the feature description.

Feature Value	Feature
02H	Enable write cache (default)
03H	Set transfer mode
04H	Enable Read Auto Relocation (default)
55H	Disable read look-ahead cache
82H	Disable write cache
84H	Disable Read Auto Relocation
AAH	Enable read look-ahead cache (default)

3.2.2.1 PIO and DMA Data-Transfer Modes

You can set the multiword DMA mode and identify the PIO data-transfer mechanism and transfer mode with the Set Features command. To set the multiword DMA mode:

1. Write Set Features command value 03_H (Set Data Transfer mode) to the Features register.
2. Write a transfer types value to the Sector Count register. The upper 5 bits of this value define the type of data transfer, and the lower 3 bits encode the mode value.

This changes word 63 of the Identify Drive command to the mode you enter in the Sector Count register.

The following table identifies allowable transfer types values:

Data-Transfer Mechanism		Transfer Types value	
Mechanism name	Mode value	Data Upper 5 bits	Lower 3 bits
PIO Transfer Mode (default)	2	00000	000
PIO Transfer Mode: Set PIO Mode = 2	2	00000	001
PIO Flow Control Transfer Mode: Set PIO Mode = 0	0	00001	000
PIO Flow Control Transfer Mode: Set PIO Mode = 1	1	00001	001
PIO Flow Control Transfer Mode: Set PIO Mode = 2	2	00001	010
PIO Flow Control Transfer Mode: Set PIO Mode = 3	3	00001	011
PIO Flow Control Transfer Mode: Set PIO Mode = 4)	4	00001	100
Multiword DMA Mode	0	00100	000
Multiword DMA Mode	1	00100	001
Multiword DMA Mode	2	00100	010
Reserved	—	01000	<i>nnn</i>

Note. If the drive does not support a commanded mode, it returns a 04 aborted command error.

3.2.3 Standby timer timeout period

The Idle command and Standby command Sector Count registers are used to activate the Standby timer. The host can enable the Standby timer by placing a value in the sector-count register of the Idle command or Standby command. The value corresponds to a predetermined period of drive inactivity. The table below lists the values the Seagate drives use and their corresponding timeout period.

Sector Count Register contents	Corresponding timeout period
0 (0H)	Timeout disabled
1–12 (1H–CH)	value = 60 seconds
13–240 (DH–F0H)	(value * 5) seconds
241–251 (F1H–FBH)	(value – 240) * 30) minutes
252 (FCH)	21 minutes
253 (FDH)	8 hours
254 (FEH)	Reserved
255 (FFH)	21 minutes 15 seconds

The drives are shipped with the Standby timer disabled.

3.2.4 Sleep command (99H, E6H)

This command performs the same function as the Standby Immediate command (94H, E0H).

3.2.5 Auto Relocation

This feature allows the drive to identify grown media defects and to reallocate the sector without host intervention using both Read and Write Auto Relocation.

The Read Relocation can be disabled by using the Set Feature command Disable Read Auto Relocation, feature value 84H. This feature is not implemented for the Read Long command.

The Write Relocation, in addition to write cache, can be disabled by using the Set Feature command Disable Write Cache, feature value 82_H. This feature is not implemented for the Write Long command.

Write Relocation and write cache are both disabled using value 82_H. These features are mutually exclusive.

3.2.6 S.M.A.R.T. command (B0_H)

Self-Monitoring, Analysis and Reporting Technology (S.M.A.R.T.) is an emerging technology that provides near-term failure prediction for disc drives. When S.M.A.R.T. is enabled, the Seagate drive monitors predetermined attributes within itself that are susceptible to degradation over time. S.M.A.R.T. makes a status report available so that the host can prompt the user to back up the drive if self-monitoring determines that a failure is likely. Not all failures are predictable. S.M.A.R.T. predictability is limited to only those attributes the drive can monitor.

The S.M.A.R.T. feature is disabled at the factory. You must have a BIOS, software driver or application software that supports S.M.A.R.T. to enable this feature. The table below shows the S.M.A.R.T. command codes the Seagate drives use.

Note. To implement a S.M.A.R.T. command, the host must write the value 0x4F to Cylinder_lo register and the value 0xC2 to the Cylinder_hi register at the same time it writes the S.M.A.R.T. command code to the Features register. If these values are not included with the command code, the command will be aborted and 0x04 (abort) will be written to the Error register.

Command code	Feature description
D2 _H	Enable/disable attribute autosave
D8 _H	Enable operation
D9 _H	Disable operation
DA _H	Return S.M.A.R.T. status

Appendix. Timing diagrams

Without IORDY, the drives operate at programmed I/O timing specifications, as shown below.

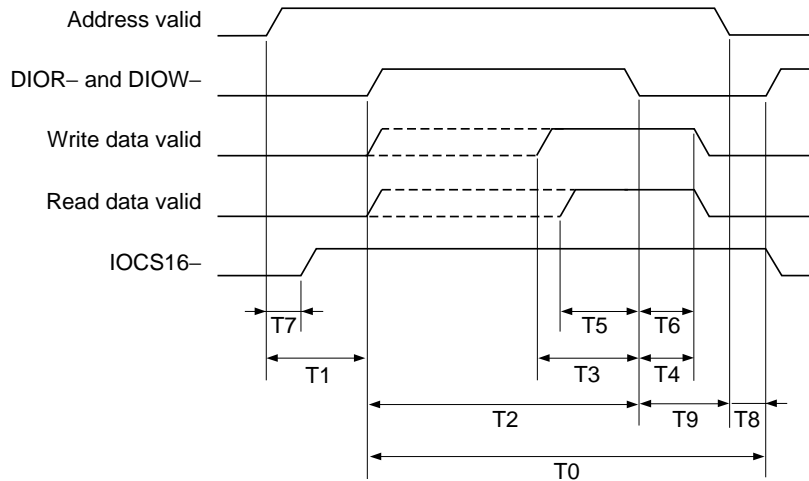

Figure 8. Programmed I/O timing without IORDY

Time	Description	Min	Max
T0	Cycle time	200 nsec	—
T1	Drives address (CS1FX-, CS3FX-, DA0, DA1 and DA2) valid and DIOR- and DIOW setup	30 nsec	—
T2	DIOW- or DIOR- pulse width	80 nsec	—
T3	DIOW- data setup	30 nsec	—
T4	DIOW- data hold	15 nsec	—
T5	DIOR- data setup	20 nsec	—
T6	DIOR- data hold	5 nsec	—
T7	DIOW- or DIOR- to address valid hold	—	40 nsec
T8	DIOW- false to write data hold	—	30 nsec
T9	DIOR- false to read data hold	10 nsec	—

When using IORDY, the drives operate at programmed timing specifications, as shown below.

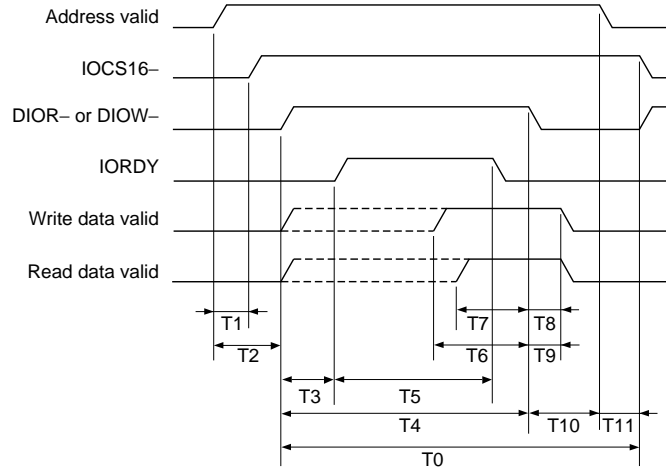

Figure 9. Programmed I/O timing with IORDY

Time	Description	Min	Max
T0	Cycle time	120 nsec	—
T1	Address valid until IOCS16- is asserted	—	30 nsec
T2	Drive address (CS1FX-, CS3FX-, DA0, DA1 and DA2) valid before DIOR- or DIOW- setup	25 nsec	—
T3	IORDY setup time	—	—
T4	DIOW- or DIOR- pulse width (8-bit)	70 nsec	—
	DIOW- or DIOR- pulse width (16-bit)	70 nsec	—
T5	IORDY pulse width	—	1,250 nsec
T6	DIOW- data setup	20 nsec	—
T7	DIOR- data setup	20 nsec	—
T8	DIOR- data hold	5 nsec	—
T9	DIOW- data hold	10 nsec	—
T10	DIOW- or DIOR- to address valid hold	5 nsec	—
T11	Address valid until IOCS16- is negated	—	25 nsec

The drives operate at multiword DMA mode 2 timing specifications, as shown below.

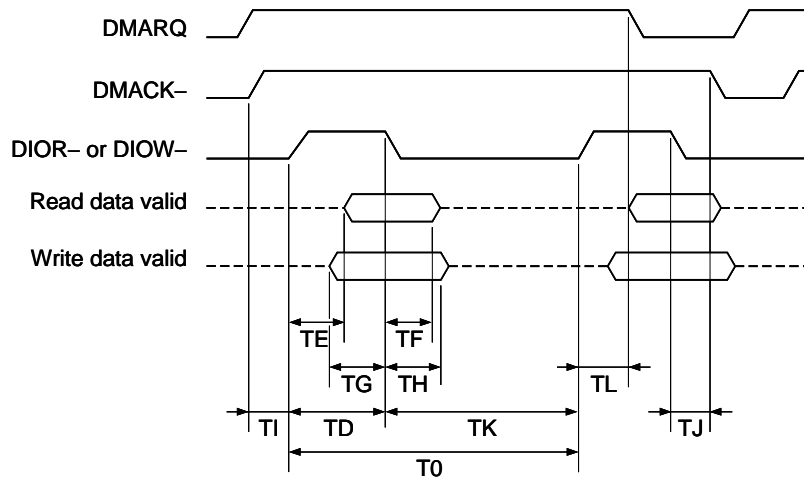
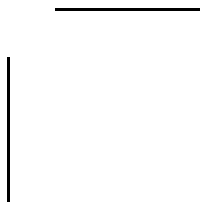
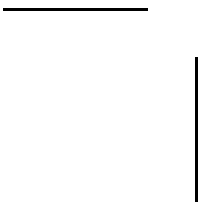
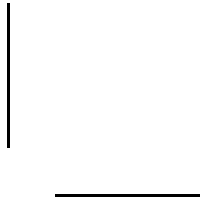
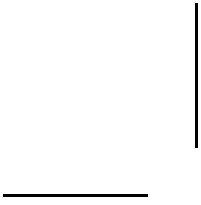
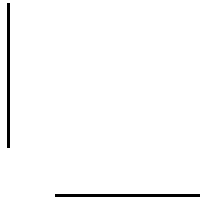
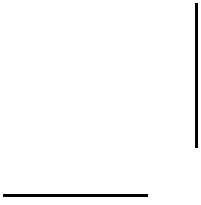
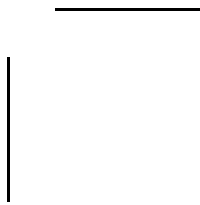
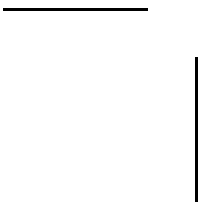
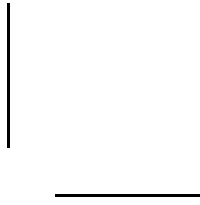
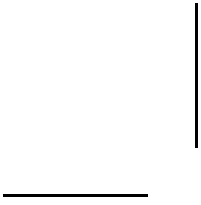

Figure 10. Multiword DMA timing

Time	Description	Min	Max
T0	Cycle time	120 nsec	—
TD	DIOW- or DIOR- pulse width (16-bit)	70 nsec	—
TE	DIOW- data access	—	—
TF	DIOW- data hold	5 nsec	—
TG	DIOW- data setup	20 nsec	—
TH	DIOW- data hold	10 nsec	—
TI	DMACK- to DIOR- or DIOW- setup	0 nsec	—
TJ	DIOW- or DIOW- to DMACK- hold	5 nsec	—
TK _R	DIOR- negated pulse width	25 nsec	—
TK _W	DIOW- negated pulse width	25 nsec	—
TL _R	DIOR- to DMARQ delay	—	35 nsec
TL _W	DIOW- to DMARQ delay	—	25 nsec







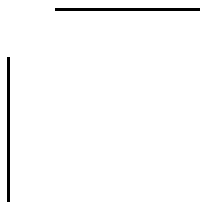
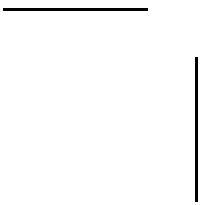
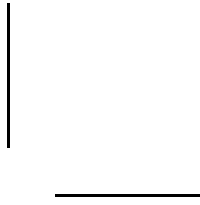
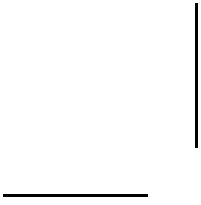



Seagate Technology, Inc.
920 Disc Drive, Scotts Valley, California 95066, USA

Publication Number: 36347-101, Rev. C, Printed in USA